

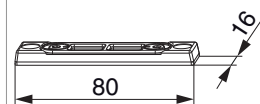



26731 - Scontro catenaccio battuta liscia/17 2 fori pressione - 1 mm argento

Disegni tecnici



				L	B	H		Nº
argento	Scontro catenaccio battuta liscia/17	2 fori	pressione - 1 mm	80	16	6,5	100	26731

Sezioni profilo

A12 battuta liscia PB18 - 1 anta

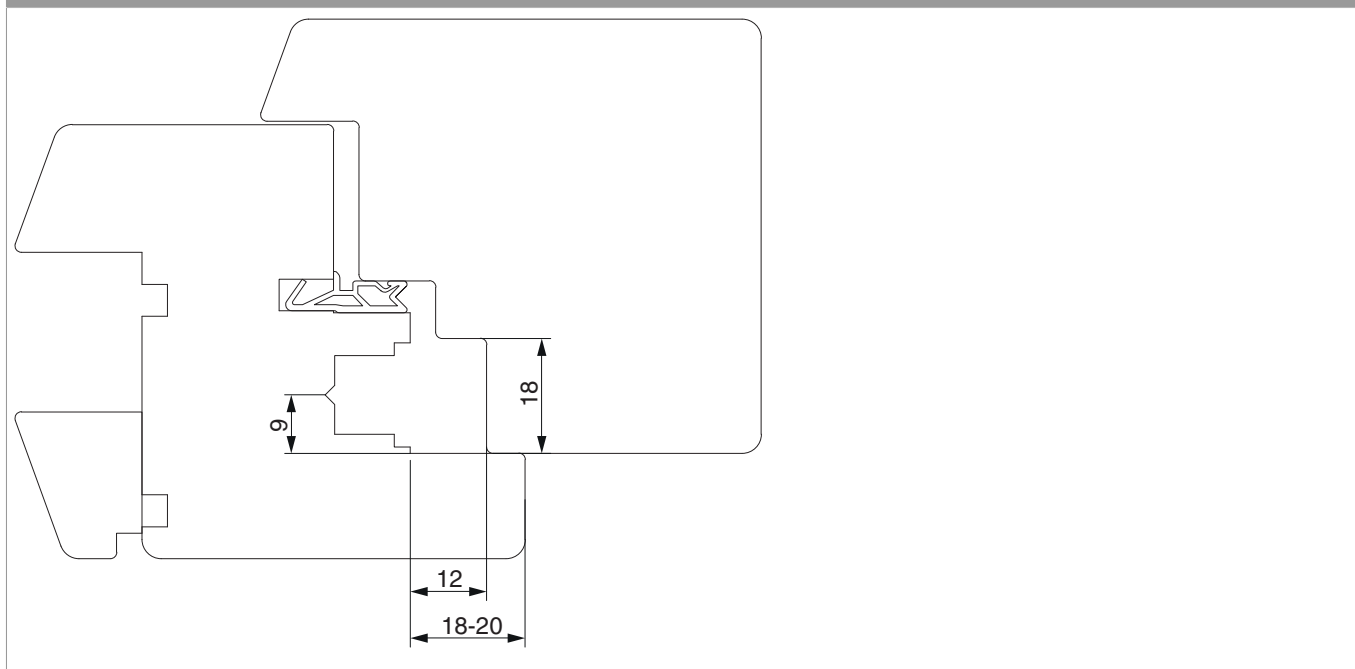

A12 battuta liscia PB18 - 2 ante

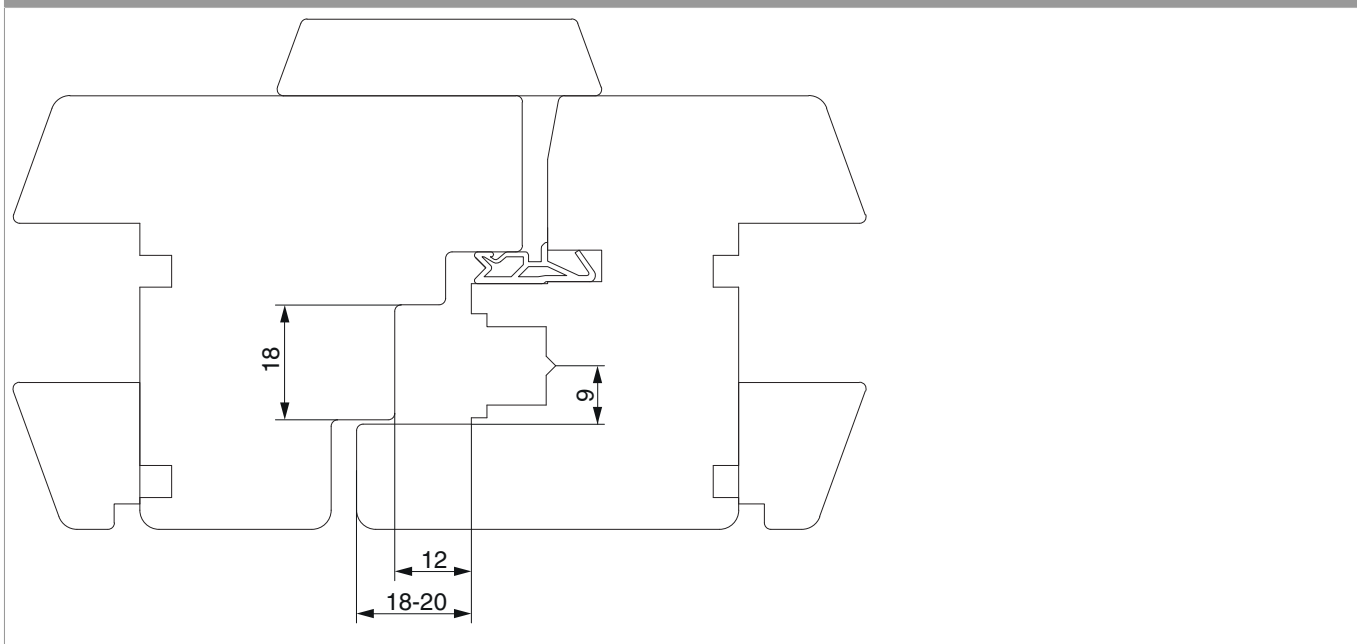

Posizionamento degli scontri

Finestra a 2 ante con 1 catenaccio

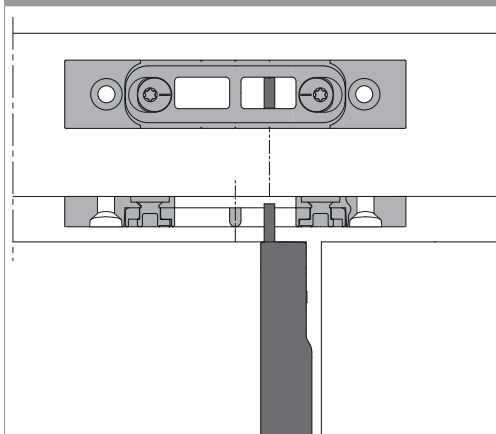

Allineare il centro dell'uscita puntale alla tacca

Finestra a 2 ante con 2 catenacci

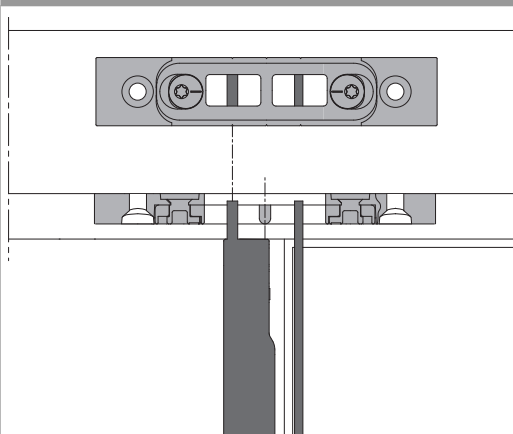

Centro scontro = centro cava ferramenta

Regolazione pressione

sullo scontro

