

## 201731 - Cremonese A-B Multi Matic 660 E15 fix HBB 431-660 HM190 argento

### Disegni tecnici

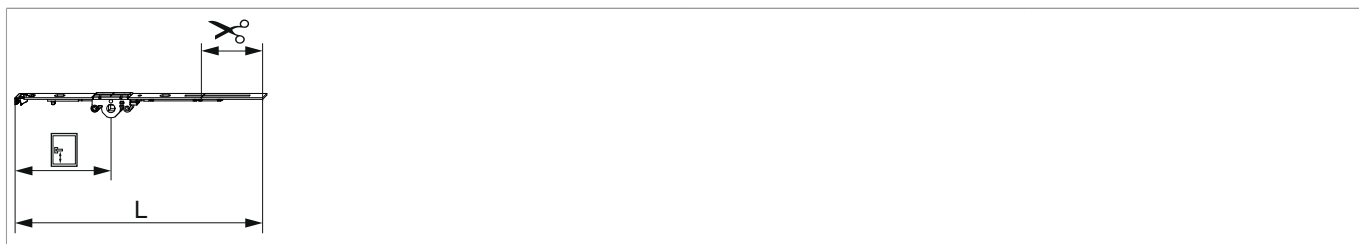

		<b>L</b>						<b>Nº</b>
argento	660	556,5	15	190	431 - 660	240,5	20	201731 <sup>1)</sup>

<sup>1)</sup> Per l'avvitamento del frontale usare il fermo per frontale (cod. 213287)

### Tabella posizionamento viti

<b>Nº</b>		1	2	3	4	5	6	7	8	9	10	11	12	13	14
201731	2	18,5	91,5												

### Tabella punti di chiusura

<b>Nº</b>		Z1	Z2	Z3	Z4	
201731	0					

### Dime

			<b>Nº</b>
Dima forature per fori martellina MM	per punta 3 mm	1	203861
Dima forature per fori martellina MM	per punta D=3 mm e D=12 mm	1	203862



### Quote della scatola cremonese

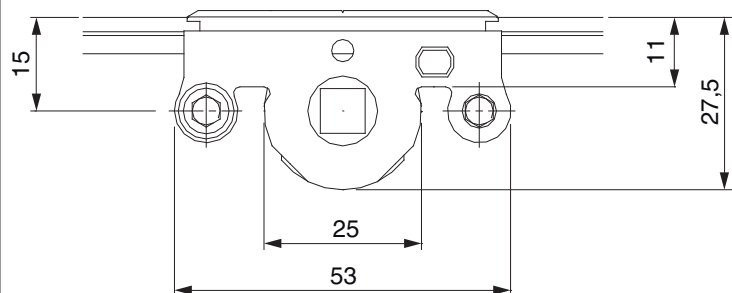

- Larghezza fresata per scatola cremonese 12 mm
- Per fissaggio maniglia utilizzare viti SPAX Ø 5 mm o viti M5.

### Schema di fresata

per PVC e alluminio

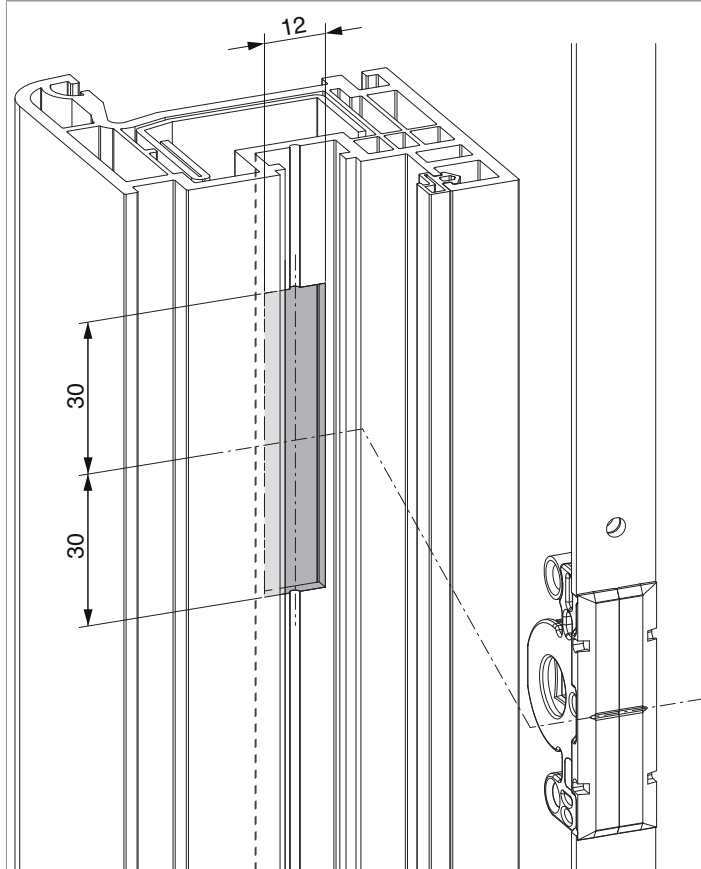

## Schema di foratura

Per serramenti in legno

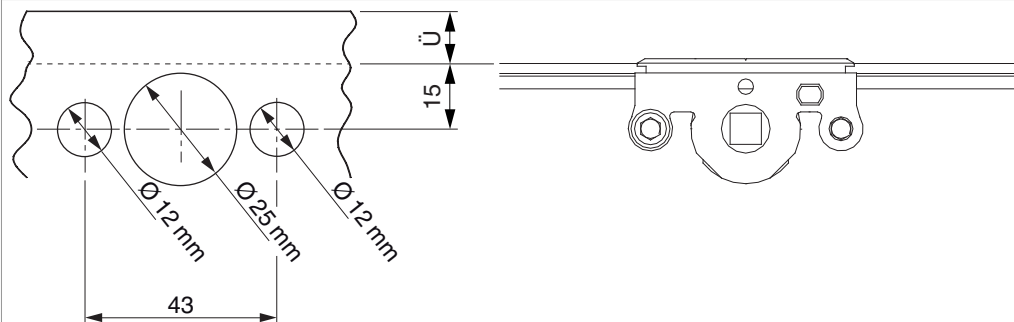

Per serramenti in PVC e alluminio

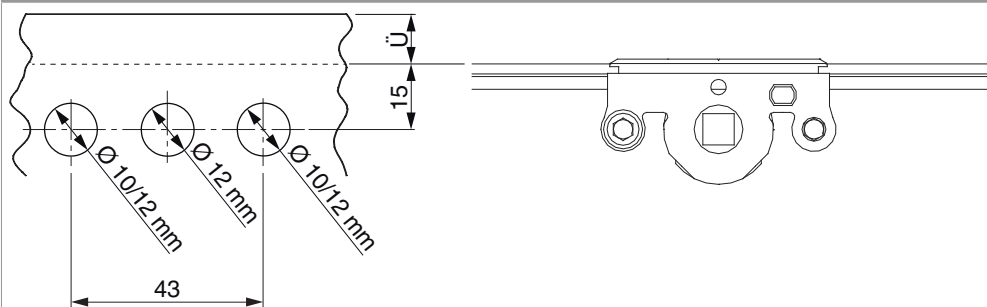

## Schema di tranciatura

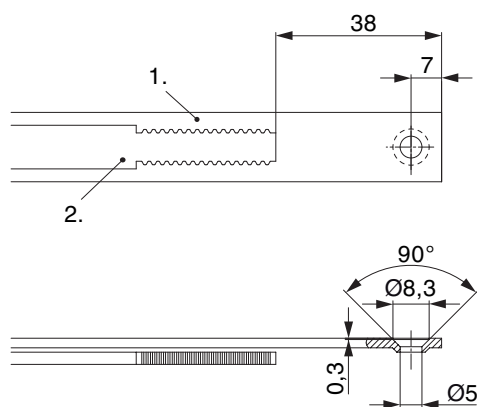

• Consigliamo di trattare il taglio dei componenti TRICOAT-PLUS con la vernice di ritocco TRICOAT-PLUS (cod. 358440).

1. Frontale  
2. Asta mobile



## Collegamento a clips

Agganciare collegamenta a clips

①

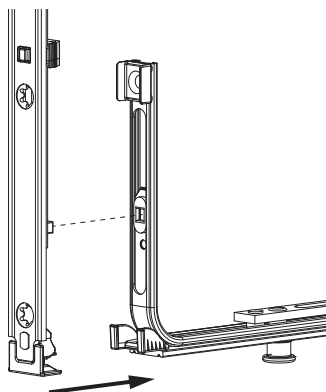

②

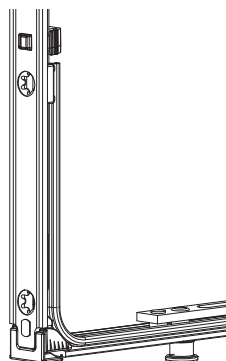

Sganciare collegamento clips

①

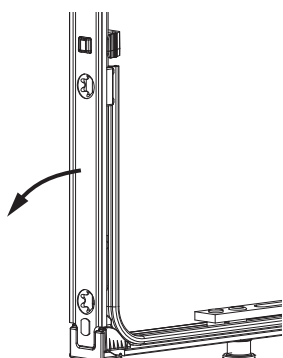

②

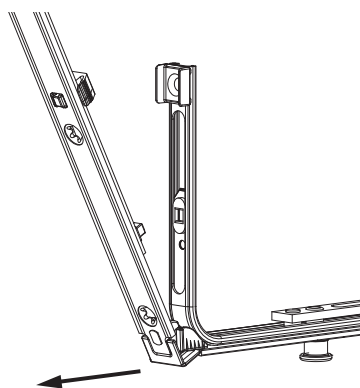

③

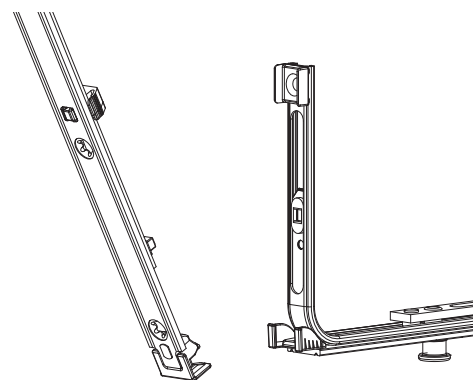

## Collegamento scarpetta dentata

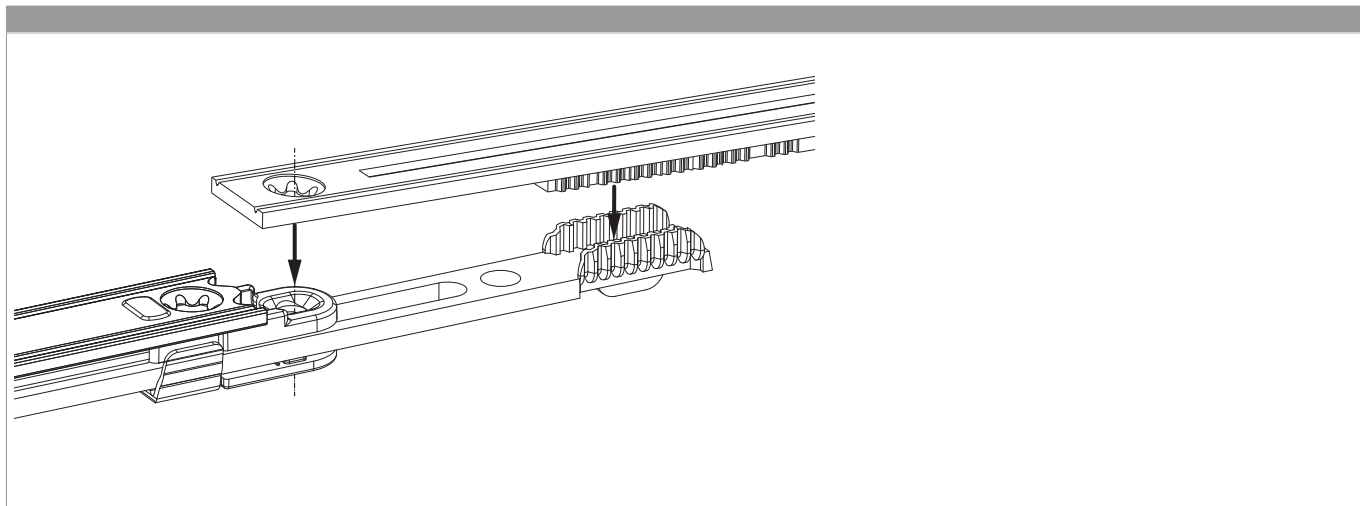

## Regolazione pressione

